

**CBSE Board**  
**Class X Mathematics**  
**Sample Paper 2 (Standard)**

**Time: 3 hrs**

**Total Marks: 80**

**General Instructions:**

1. This question paper contains **two parts** A and B.
2. Both **Part A** and **Part B** have internal choices.

**Part - A:**

1. It consists **two sections** - I and II.
2. **Section I** has **16 questions** of **1 mark** each. Internal choice is provided in **5 questions**.
3. **Section II** has **4 questions** on **case study**. Each case study has **5 case-based sub-parts**. An examinee is to attempt any **4 out of 5 sub-parts**. Each subpart carries **1 mark**.

**Part - B:**

1. It consists **three sections** - III, IV and V
2. **Section III: Question No 21 to 26** are **Very short answer** Type questions of **2 marks** each.
3. **Section IV: Question No 27 to 33** are **Short Answer Type** questions of **3 marks** each.
4. **Section V: Question No 34 to 36** are **Long Answer Type** questions of **5 marks** each.
5. Internal choice is provided in **2 questions of 2 marks, 2 questions of 3 marks and 1 question of 5 marks**

**Part A**

**Section I**

**Section I has 16 questions of 1 mark each.**

**(Internal choice is provided in 5 questions)**

1. Express a decimal number  $0.\overline{8}$  in its simplest form.

**OR**

Without actually performing the long division, state whether  $\frac{17}{8}$  is a terminating decimal expansion or a non-terminating repeating decimal expansion.

2. Find the value(s) of  $m$ , for which the lines represented by the following pair of linear equations  $3x + 6y - 15 = 0$  and  $9x + 18y - m = 0$  be coincident.

- In  $\Delta ABC$ , right angled at B,  $AB = 12$  cm and  $BC = 5$  cm then what will be the value of  $\sin A$ .
- Given that  $\sin 2x = 1$  and  $\cos y = \frac{\sqrt{3}}{2}$ , then find the value of  $x - y$ .
- What are the coordinates of a point which divides the line segment joining the points  $A(-3, 6)$  and  $B(5, 2)$  in the ratio  $1 : 3$ ?

**OR**

Find the distance of a point  $(-24, 7)$  from the origin (in units).

- A number  $x$  is chosen from the numbers  $-3, -2, -1, 0, 1, 2, 3$ . Then find the probability that  $|x| < 2$ .

**OR**

What is the probability for a student to get pass marks in an examination?

- If the polynomial  $p(x) = 3x^2 + 7x - 3$  is divided by another polynomial  $x^2 - 2$  then find the remainder.
- 2 cubes each with side 4 cm are joined to form a cuboid. Find the surface area of the resulting cuboid.
- In the figure,  $ST$  is drawn parallel to the side  $QR$ .

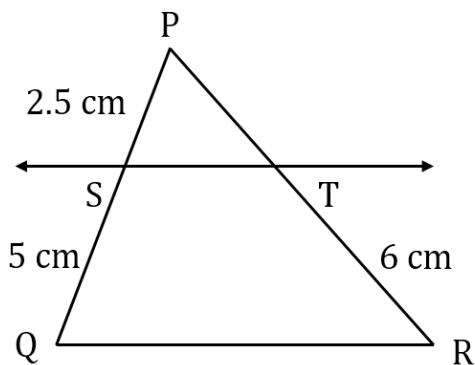

Then, what is the length of  $PT$ ?

- Find the roots of the equation  $x^2 - 3\sqrt{3}x + 6 = 0$ .

**OR**

Find discriminant for the equation  $x^2 - 2x + 1 = 0$ .

- If  $\frac{4}{5}$ ,  $a$  and  $2$  are three consecutive terms of an AP then find the value of  $a$ .

**OR**

The first and last terms of an A.P. are  $1$  and  $11$ . If the sum of all its terms is  $36$ , then find the number of terms in the A.P.

12. In the given figure,  $AR = 5$  cm,  $BR = 4$  cm and  $AC = 11$  cm. What is the length of  $BC$ ?

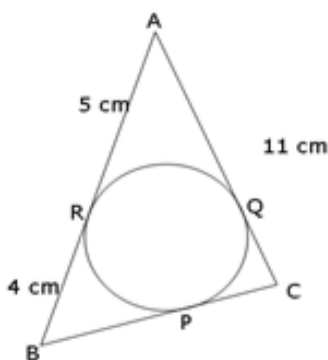

13. If the system of equations  $2x + 3y = 5$ ,  $4x + ky = 10$  has infinitely many solutions, then find the value of  $k$ .
14. The distribution below gives the weights of 30 students of a class.

Weight (in kg)	40 – 45	45 – 50	50 – 55	55 – 60	60 – 65	65 – 70	70 – 75
Number of students	2	3	8	6	6	3	2

In the given data what is the lower limit of the median class in the given data?

15. Find the area of a triangle (in sq. units) whose vertices are  $(7, -2)$ ,  $(5, 1)$  and  $(3, 2)$ .
16. If  $r$ ,  $h$  and  $l$  denote respectively the radius of base, height and slant height of a right circular cone, then what is the formula of total surface area?

## Section II

(Q 17 to Q 20 carry 4 marks each)

**Case study based questions are compulsory. Attempt any four sub parts of each question. Each subpart carries 1 mark**

17. **Case Study based-1**  
**SUN ROOM**

The diagrams show the plans for a sun room. It will be built onto the wall of a house. The four walls of the sunroom are square clear glass panels. The roof is made using

- Four clear glass panels, trapezium in shape, all the same size
- One tinted glass panel, half a regular octagon in shape



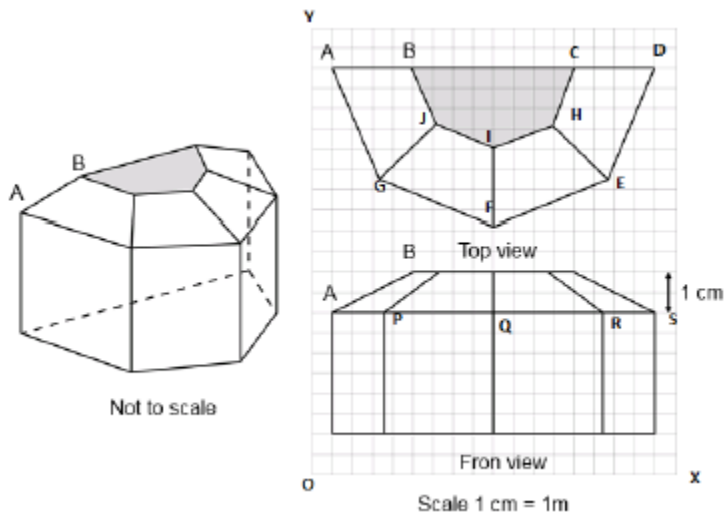

**(a) Refer to Top View**

Find the mid-point of the segment joining the points I (9, 16) and H (12, 15).

- (i)  $(33/2, 15/2)$
- (ii)  $(3/2, 1/2)$
- (iii)  $(21/2, 31/2)$
- (iv)  $(1/2, 3/2)$

**(b) Refer to Front View**

The distance of the point Q from the x-axis is

- (i) 4 (ii) 6 (iii) 19 (iv) 25

**(c) Refer to Top View**

The distance between the points A and D is

- (i) 4 (ii) 8 (iii) 16 (iv) 20

**(d) Refer to Front View**

Find the co-ordinates of the point which divides the line segment joining the points A and B in the ratio 3:1 internally.

- (i) (8.5, 2.0) (ii) (4.0, 9.5) (iii) (3.0, 7.5) (iv) (4.0, 8.5)

**(e) Refer to Front View**

If a point (x,y) is equidistant from the Q(9,8) and S(17,8), then

- (i)  $x+y=13$  (ii)  $x-13=0$  (iii)  $y-13=0$  (iv)  $x-y=13$

**18. Case Study Based- 2**

**SCALE FACTOR AND SIMILARITY**

**SCALE FACTOR**

A scale drawing of an object is the same shape as the object but a different size.

The scale of a drawing is a comparison of the length used on a drawing to the length it represents. The scale is written as a ratio.

### SIMILAR FIGURES

The ratio of two corresponding sides in similar figures is called the scale factor.

$$\text{Scale factor} = \frac{\text{length in image}}{\text{corresponding length in object}}$$

If one shape can become another using Resizing then the shapes are Similar

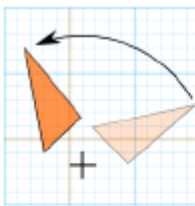
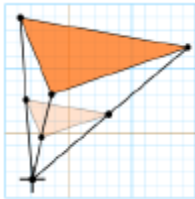

Rotation or Turn

Reflection or Flip

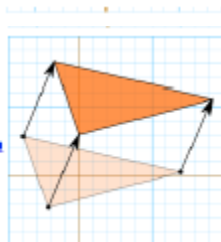
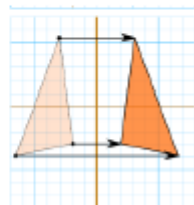

Translation or Slide

Hence, two shapes are Similar when one can become the other after a resize, flip, slide or turn.

(a) A model of a boat is made on the scale of 1:5. The model is 150cm long. The full size of the boat has a width of 60cm. What is the width of the scale model?

- (i) 20cm
- (ii) 12cm
- (iii) 15cm
- (iv) 240cm





- (b) What will effect the similarity of any two polygons?
- They are flipped horizontally
  - They are dilated by a scale factor
  - They are translated down
  - They are not the mirror image of one another
- (c) If two similar triangles have a scale factor of  $a : b$ . Which statement regarding the two triangles is true?
- The ratio of their perimeters is  $3a : b$
  - Their altitudes have a ratio  $a : b$
  - Their medians have a ratio  $a/2 : b$
  - Their angle bisectors have a ratio  $a^2 : b^2$
- (d) The shadow of a stick 10m long is 4m. At the same time the shadow of a tree 22.5m high is

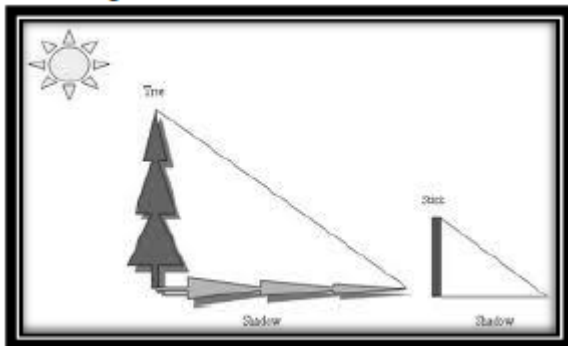

- 3m
  - 3.5m
  - 5m
  - 9m
- (e) Below you see a student's mathematical model of a farmhouse roof with measurements. The attic floor, ABCD in the model, is a square. The beams that support the roof are the edges of a rectangular prism, EFGHLMN. E is the middle of AT, F is the middle of BT, G is the middle of CT, and H is the middle of DT. All the edges of the pyramid in the model have length of 12 m.

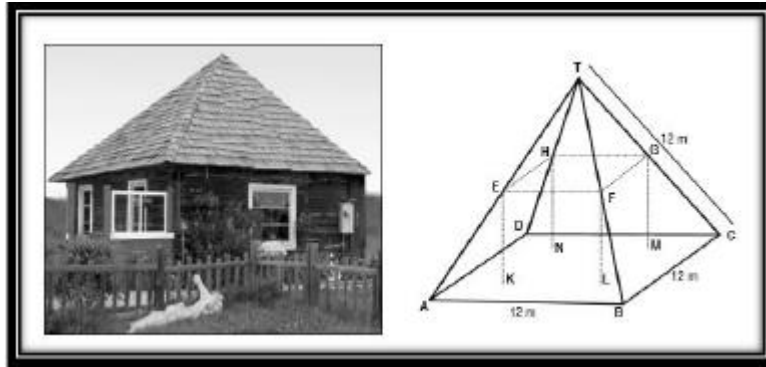

What is the length of EF, where EF is one of the horizontal edges of the block?

- (i) 24m
- (ii) 3m
- (iii) 6m
- (iv) 10m

**19. Case Study Based- 3**

**Applications of Parabolas-Highway Overpasses/Underpasses**  
**A highway underpass is parabolic in shape.**

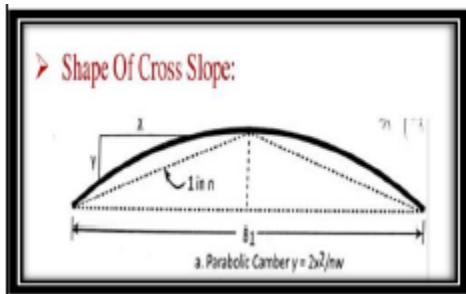

**Parabola**

A parabola is the graph that results from  $p(x)=ax^2 + bx + c$

Parabolas are symmetric about a vertical line known as the Axis of Symmetry.

The Axis of Symmetry runs through the maximum or minimum point of the parabola which is called the

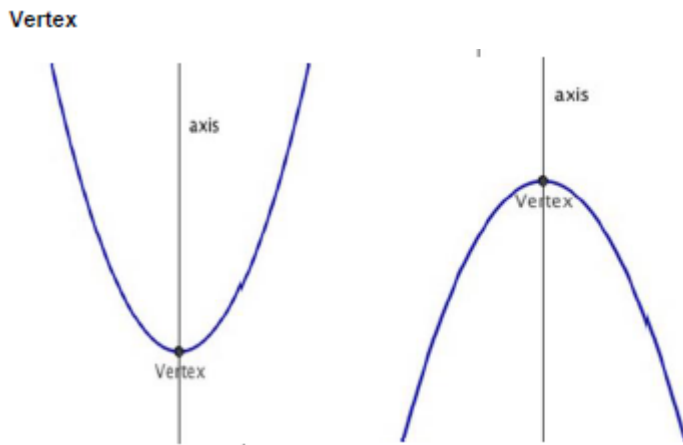

- (a) If the highway overpass is represented by  $x^2 - 10x + 16$ . Then its zeroes are  
 (i)  $(2, -4)$  (ii)  $(8, 2)$  (iii)  $(-8, 2)$  (iv)  $(-4, -4)$
- (b) The highway overpass is represented graphically.  
 Zeroes of a polynomial can be expressed graphically. Number of zeroes of polynomial is equal to number of points where the graph of polynomial  
 (i) Intersects x-axis  
 (ii) Intersects y-axis  
 (iii) Intersects y-axis or x-axis  
 (iv) None of the above
- (c) Graph of a quadratic polynomial is a  
 (i) straight line  
 (ii) circle  
 (iii) parabola  
 (iv) ellipse
- (d) The representation of Highway Underpass whose one zero is 6 and product of the zeroes is 0, is  
 (i)  $x^2 - 6x + 2$   
 (ii)  $x^2 - 12x + 36$   
 (iii)  $x^2 - 36$   
 (iv)  $x^2 - 3$
- (e) The number of zeroes that polynomial  $f(x) = (x - 3)^2 + 4$  can have is:  
 (i) 1  
 (ii) 2  
 (iii) 0  
 (iv) 3



20. Case Study Based- 4

100m RACE

A stopwatch was used to find the time that it took a group of students to run 100m.

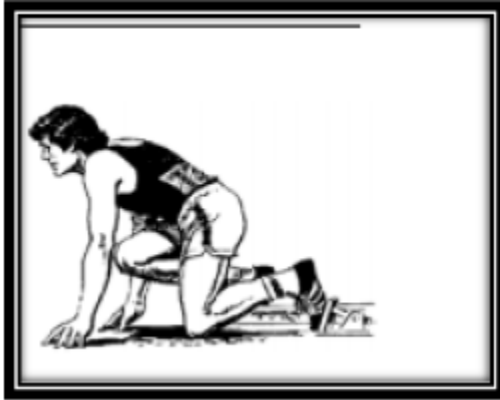

Time(in sec)	0 - 20	20 - 40	40 - 60	60 - 80	80 - 100
No. of students	8	10	13	6	3

- (a) Estimate the mean time taken by a student to finish the race.
- (i) 54
  - (ii) 63
  - (iii) 43
  - (iv) 50
- (b) What will be the lower limit of the modal class?
- (i) 20
  - (ii) 40
  - (iii) 60
  - (iv) 80
- (c) The construction of cumulative frequency table is useful in determining the
- (i) Mean
  - (ii) Median
  - (iii) Mode
  - (iv) All of the above
- (d) The sum of upper limits of median class and modal class is
- (i) 60
  - (ii) 120
  - (iii) 80
  - (iv) 140
- (e) How many students finished the race within 80 seconds?
- (i) 18
  - (ii) 37
  - (iii) 31
  - (iv) 8

## Part B

All questions are compulsory. In case of internal choices, attempt any one.

### Section III

(Q 21 to Q 26 carry 2 marks each)

21. Show that the tangents at the end points of a diameter of a circle are parallel.
22. The radii of two circles are 19 cm and 9 cm respectively. Find the radius of the circle which has its circumference equal to the sum of the circumferences of the two circles.

OR

Two circular pieces of equal radii and maximum area, touching each other are cut out from a rectangular card board of dimensions 14 cm  $\times$  7 cm. Find the area of the remaining card board. (Use  $\pi = \frac{22}{7}$ )

23. A wooden article was made by scooping out a hemisphere from each end of a solid cylinder, as shown in the given figure. If the height of the cylinder is 10 cm, and its base is of radius 3.5 cm, find the total surface area of the article.

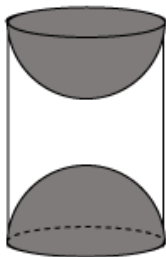

24. An electrician has to repair an electric fault on a pole of height 4 m. He needs to reach a point 1.3 m below the top of the pole to undertake the repair work. What should be the length of the ladder which makes an angle of  $60^\circ$  with the road to help him reach the required position?

OR

Find the angular elevation of the sun when the shadow of a 10 m long pole is  $10\sqrt{3}$  m.

25. Write the next term of the AP  $\sqrt{2}, \sqrt{8}, \sqrt{18}, \dots$
26. A die is thrown at once. What is the probability of getting a prime number?



## Section IV

(Q 27 to Q 23 carry 3 marks each)

27. Determine the ratio in which the line  $3x + y - 9 = 0$  divides the segment joining the points (1, 3) and (2, 7).

**OR**

The point P divides the join of (2, 1) and (-3, 6) in the ratio 2: 3. Does P lie on the line  $x - 5y + 15 = 0$ ?

28. Draw a line segment of length 7.6 cm and divide it in the ratio 5:8. Measure the two parts.

29. The table shows the ages of the patients admitted in a hospital during a year. Find the mode and the mean of the data given above. Compare and interpret the two measures of central tendency.

Age (in years)	5-15	15-25	25-35	35-45	45-55	55-65
Number of patients	6	11	21	23	14	5

**OR**

Find the mode for the following data which gives the literacy rate (in %) in 40 cities of India.

Literacy rate (%)	45-55	55-65	65-75	75-85	85-95
No. of cities	4	11	12	9	4

30. Explain why  $\overline{3.1416}$  is a rational number.
31. On dividing  $x^3 - 3x^2 + x + 2$  by a polynomial  $g(x)$ , the quotient and remainder were  $x - 2$  and  $-2x + 4$ , respectively. Find  $g(x)$ .
32. The sum of the numerator and denominator of a fraction is 8. If 3 is added to both the numerator and the denominator, the fraction becomes  $\frac{3}{4}$ . Find the fraction
33. In a circle of radius 21 cm, an arc subtends an angle of  $60^\circ$  at the centre. Find:  
a. The length of the arc  
b. Area of the sector formed by the arc  
c. Area of the segment formed by the corresponding chord.

**OR**

On a circular table cover of radius 42 cm, a design is formed by a girl leaving an



equilateral triangle ABC in the middle, as shown in the figure. Find the covered area of the design.

$$\left[ \text{Use } \sqrt{3} = 1.73 \text{ and } \pi = \frac{22}{7} \right]$$

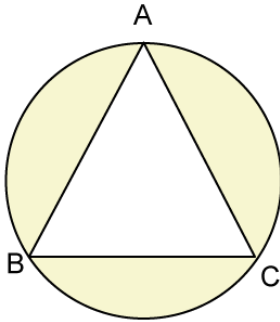

### Section V

(Q 34 to Q 36 carry 5 marks each)

34. On a window of a house in a street,  $h$  metres above the ground, the angles of elevation and depression of the top and the foot of another house on the opposite side of the street are  $\alpha$  and  $\beta$  respectively. Show that the height of the opposite house is  $h(1 + \tan \alpha \cdot \cot \beta)$  metres.

**OR**

From the top of a light house 200m high, the angles of depression of two ships on opposite sides of it are  $45^\circ$  and  $30^\circ$  respectively. Find the distance between two ships to the nearest metre.

35. Prove that the ratio of the areas of two similar triangles is equal to the ratio of the squares of their corresponding sides. Formatting and numbering issue.
36. A copper wire of 4 mm diameter is evenly wound around a cylinder whose length is 24 cm and diameter 20 cm so as to cover the whole surface. Find the length and weight of the wire assuming the density to be  $8.68 \text{ gm/cm}^3$ .



**CBSE Board**  
**Class X Mathematics**  
**Sample Paper 2 (Standard) – Solution**

---

**Part A**

**Section I**

1. Let  $x = 0.\overline{8}$  ..... (i)  
 $\Rightarrow 10x = 8.\overline{8}$  ..... (ii)  
(ii) - (i)  
 $\Rightarrow 10x - x = 8$   
 $\Rightarrow 9x = 8$   
 $\Rightarrow x = 8/9$

**OR**

$$\frac{17}{8}$$

Prime factorisation of  $8 = 2^3 5^0$

Since the prime factorisation of 8 is in the form of  $2^n 5^m$

$\Rightarrow$  The decimal expansion of  $\frac{17}{8}$  is terminating.

2. For the two lines  $a_1x + b_1y + c_1 = 0$  and  $a_2x + b_2y + c_2 = 0$  to be coincident,

we must have  $\frac{a_1}{a_2} = \frac{b_1}{b_2} = \frac{c_1}{c_2}$ .

The given equation of lines are  $3x + 6y - 15 = 0$  and  $9x + 18y - m = 0$

$$\text{As } \frac{a_1}{a_2} = \frac{3}{9} = \frac{1}{3}, \frac{b_1}{b_2} = \frac{6}{18} = \frac{1}{3}$$

$$\text{Therefore, } \frac{c_1}{c_2} = \frac{1}{3} \Rightarrow \frac{-15}{-m} = \frac{1}{3} \Rightarrow m = 45$$

Hence, the value of  $m$  is 45.

3. In  $\triangle ABC$ , right angled at B,  $AB = 12$  cm and  $BC = 5$  cm.

Applying Pythagoras theorem, we have

$$AC^2 = AB^2 + BC^2 = (12)^2 + (5)^2 = 144 + 25 = 169$$

$$\Rightarrow AC = \sqrt{169} = 13 \text{ cm}$$

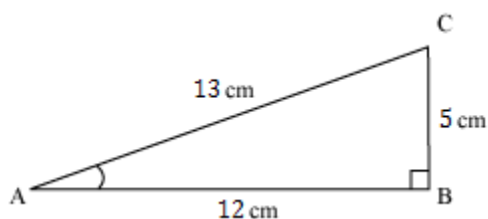

$$\sin A = \frac{\text{side opposite to } \angle A}{\text{Hypotenuse}} = \frac{BC}{AC} = \frac{5}{13}$$

4. Given  $\sin 2x = 1$

$$\Rightarrow 2x = \sin^{-1} 1 = \frac{\pi}{2}$$

$$\Rightarrow x = \frac{\pi}{4}$$

$$\text{Also, } \cos y = \frac{\sqrt{3}}{2}$$

$$\Rightarrow y = \cos^{-1} \frac{\sqrt{3}}{2} = \frac{\pi}{6}$$

$$\Rightarrow y = \frac{\pi}{6}$$

$$\therefore x - y = \frac{\pi}{4} - \frac{\pi}{6} = \frac{\pi}{12}$$

Hence, the value of  $x - y$  is  $\frac{\pi}{12}$ .

5. Let  $P(x, y)$  be the point which divides the line segment  $AB$  in the ratio 1: 3. Coordinates of point  $P$ , dividing the line segment joining  $A(x_1, y_1)$  &  $B(x_2, y_2)$

internally in the ratio  $m:n$  is  $\left( \frac{mx_2 + nx_1}{m+n}, \frac{my_2 + ny_1}{m+n} \right)$

$$\text{Therefore, } x = \frac{1(5) + 3(-3)}{1+3} = -1 \text{ and } y = \frac{1(2) + 3(6)}{1+3} = 5$$

Hence, the coordinates of  $P$  are  $(-1, 5)$

**OR**

Origin is  $O(0, 0)$  and given point is  $P(-24, 7)$ .

Now, distance between two points  $(x_1, y_1)$  and  $(x_2, y_2)$  is given by

$$\sqrt{(x_1 - x_2)^2 + (y_1 - y_2)^2}$$

Therefore, distance between point  $P$  and origin is

$$\sqrt{(0 + 24)^2 + (0 - 7)^2} = \sqrt{24^2 + 7^2} = \sqrt{576 + 49} = 25$$

Hence, the distance of  $(-24, 7)$  from the origin is 25 units.

6. Total number of outcomes = 7

From the given list, numbers which satisfy  $|x| < 2$  are  $-1, 0, 1$ .

Number of favourable outcomes = 3

$$\therefore \text{Required probability} = \frac{3}{7}$$

**OR**

All possible outcomes = {Pass, Fail}

$$\Rightarrow n(S) = 2$$

Possible outcomes of passing = A = {Pass}

$$\Rightarrow n(A) = 1$$

$$\therefore \text{Required probability} = \frac{n(A)}{n(S)} = \frac{1}{2}$$

7.  $p(x) = 3x^2 + 7x - 3$  is divided by polynomial  $x^2 - 2$

$$\begin{array}{r} \phantom{x^2 - 2} \overline{) 3x^2 + 7x - 3} \\ \underline{3x^2 \phantom{+ 7x} - 6} \phantom{- 3} \\ \phantom{3x^2} + 3 \phantom{- 3} \\ \phantom{3x^2} \underline{7x + 3} \phantom{- 3} \\ \phantom{3x^2} \phantom{7x} + 3 \phantom{- 3} \end{array}$$

Hence, the remainder is  $7x + 3$ .

8. Dimensions of the resulting cuboid will be 4 cm, 4 cm, 8 cm.

Surface area of the cuboid

$$= 2(lb + bh + lh)$$

$$= 2(4 \times 4 + 4 \times 8 + 4 \times 8)$$

$$= 2(16 + 32 + 32)$$

$$= 2(16 + 64)$$

$$= 2 \times 80 = 160 \text{ cm}^2$$

Hence, the surface area of the resulting cuboid is 160 cm

9. Let  $PT = x$  cm

Given: In  $\Delta PQR$ ,  $ST \parallel QR$

Using Basic proportionality theorem, we have

$$\frac{PS}{SQ} = \frac{PT}{TR}$$

$$\Rightarrow \frac{2.5}{5} = \frac{x}{6}$$

$$\therefore x = 3$$

Hence, the length of  $PT$  is 3 cm.

10.  $x^2 - 3\sqrt{3}x + 6 = 0$

$$\Rightarrow x^2 - \sqrt{3}x - 2\sqrt{3}x + 6 = 0$$

$$\Rightarrow x(x - \sqrt{3}) - 2\sqrt{3}(x - \sqrt{3}) = 0$$

$$\Rightarrow (x - \sqrt{3})(x - 2\sqrt{3}) = 0$$

$$\Rightarrow x - \sqrt{3} = 0 \text{ or } x - 2\sqrt{3} = 0$$

$$\Rightarrow x = \sqrt{3} \text{ or } x = 2\sqrt{3}$$



**OR**

Given equation is  $x^2 - 2x + 1 = 0$

Comparing with  $ax^2 + bx + c = 0$

$a = 1$ ,  $b = -2$  and  $c = 1$

Discriminant =  $b^2 - 4ac = (-2)^2 - 4 = 0$

**11.** According to the question,

$$a - \frac{4}{5} = 2 - a$$

$$\Rightarrow 2a = 2 + \frac{4}{5}$$

$$\Rightarrow 2a = \frac{14}{5}$$

$$\Rightarrow a = \frac{7}{5}$$

**OR**

Given that the first and last terms of an A.P. are 1 and 11, i.e.,  $a = 1$  and  $l = 11$ .

Sum of its  $n$  terms =  $S_n = 36$

$$S_n = \frac{n}{2} (a + l)$$

$$\Rightarrow 36 = \frac{n}{2} (1 + 11)$$

$$\Rightarrow n = \frac{36}{6} = 6$$

Thus, the number of terms in the A.P. is 6.

**12.** Given,  $AR = 5$  cm,  $BR = 4$  cm and  $AC = 11$  cm

We know that the tangents drawn from a point outside a circle are equal in length.

$\Rightarrow AR = AQ = 5$  cm and  $BR = BP = 4$  cm

And  $PC = QC = AC - AQ = 11 - 5 = 6$  cm

Therefore,  $BC = BP + PC = 4$  cm +  $6$  cm =  $10$  cm

**13.** Given system of equations has infinitely many solutions.

$$\Rightarrow \frac{a_1}{a_2} = \frac{b_1}{b_2} = \frac{c_1}{c_2}$$

$$\Rightarrow \frac{2}{4} = \frac{3}{k} = \frac{-5}{-10}$$

$$\Rightarrow k = \frac{4 \times 3}{2} = 6$$



14. We may find cumulative frequencies with their respective class intervals as below

Weight (in kg)	Frequency (fi)	Cumulative frequency
40 - 45	2	2
45 - 50	3	2 + 3 = 5
50 - 55	8	5 + 8 = 13
55 - 60	6	13 + 6 = 19
60 - 65	6	19 + 6 = 25
65 - 70	3	25 + 3 = 28
70 - 75	2	28 + 2 = 30
Total (n)	30	

Cumulative frequency just greater than  $\frac{n}{2}$  (i.e.  $\frac{30}{2} = 15$ ) is 19,

belonging to class interval 55 - 60.

Median class = 55 - 60

Lower limit (l) of median class = 55

Hence, the lower limit is 55.

15. Vertices of a triangle are (7, -2), (5, 1) and (3, 2)

Area of a triangle with vertices  $(x_1, y_1)$ ,  $(x_2, y_2)$  and  $(x_3, y_3)$  is

$$= \frac{1}{2} \{x_1(y_2 - y_3) + x_2(y_3 - y_1) + x_3(y_1 - y_2)\}$$

$$\Rightarrow \text{Area} = \frac{1}{2} \{7(1 - 2) + 5(2 - (-2)) + 3(-2 - 1)\}$$

$$= \frac{1}{2} \{-7 + 20 - 9\}$$

$$= \frac{1}{2} \{4\} = 2$$

Hence, the area of the triangle is 2 sq. units.

16. If  $r$ ,  $h$  and  $l$  denote respectively the radius of base, height and slant height of a right circular cone, then total surface area is  $\pi r^2 + \pi r l$ .



## Part B

### Section II

17.

(a) Mid-point of I and H =  $\left(\frac{9+12}{2}, \frac{16+15}{2}\right) = \left(\frac{21}{2}, \frac{31}{2}\right)$

(b) The distance of the point Q from the x - axis is 6m.

(c) The distance between A and D is 16m.

(d) Coordinates of A are (1, 8) and that of B are (5, 10).

Coordinates of a point dividing AB in the ratio 3: 1 is

$$\left(\frac{3 \times 5 + 1 \times 1}{1 + 3}, \frac{3 \times 10 + 1 \times 8}{1 + 3}\right) = \left(4, \frac{19}{2}\right) = (4.0, 9.5)$$

(e) (x, y) is equidistant from Q(9, 8) and S(17, 8).

$$\Rightarrow (9 - x)^2 + (8 - y)^2 = (17 - x)^2 + (8 - y)^2$$

$$\Rightarrow 81 - 18x = 289 - 34x$$

$$\Rightarrow 16x = 208$$

$$\Rightarrow x = 13$$

$$\Rightarrow x - 13 = 0$$

18.

(a) Width of the scale model =  $\frac{1}{5} \times \text{width of the boat} = \frac{1}{5} \times 60 = 12 \text{ cm}$

(b) If any two polygons are not the mirror image of one another then their similarity will effect.

(c) We know that,

$$\text{Scale factor} = \frac{\text{length in image}}{\text{corresponding length in object}}$$

If two similar triangles have a scale factor of a: b then their altitudes have a ratio a: b

(d) This is an example of similarity.

$$\Rightarrow \frac{10}{4} = \frac{22.5}{\text{Shadow of a tree}}$$

$$\Rightarrow \text{Shadow of a tree} = \frac{90}{10} = 9 \text{ m}$$

(e) Here,  $\triangle TEF$  and  $\triangle TAB$  are similar triangles as they form the equal angles.

Therefore, the ratio of their corresponding sides is same.

As E and F are the midpoints TA and TB, so TE = 6m and TF = 6m

$$\frac{EF}{AB} = \frac{TE}{TA} = \frac{1}{2} \Rightarrow EF = 6 \text{ m}$$



19.

(a)  $x^2 - 10x + 16 = x^2 - 8x - 2x + 16 = x(x - 8) - 2(x - 8) = 0$   
 $\Rightarrow (x - 8)(x - 2) = 0$   
 $\Rightarrow x = 8$  or  $x = 2$

(b) Zeroes of a polynomial can be expressed graphically. Number of zeroes of polynomial is equal to number of points where the graph of polynomial **Intersects x - axis.**

(c) Graph of a quadratic polynomial is a Parabola.

(d) A highway underpass is parabolic in shape and a parabola is the graph that results from  $p(x) = ax^2 + bx + c$  which has two zeroes. (As it is a quadratic polynomial)

Product of zeroes = 36 and one of the zero = 6  $\Rightarrow$  other zero = 6

$x^2 - (\text{sum of zeroes})x + \text{product of zeroes}$   
 $= x^2 - 12x + 36$

(e)  $f(x) = (x - 3)^2 + 4 = x^2 - 6x + 13$  is a Quadratic Polynomial.

The number of zeroes that  $f(x)$  can have is 2.

20.

(a)

Time (in sec)	No. of students(f)	X	fx
0 - 20	8	10	80
20 - 40	10	30	300
40 - 60	13	50	650
60 - 80	6	70	420
80 - 100	3	90	270
	$\Sigma f = 40$		$\Sigma fx = 1720$

Mean time taken by a student to finish the race =  $1720/40 = 43$  seconds

(b) The modal class is 40 - 60 as it has the highest frequency i.e 13.

Lower limit of the modal class = 40

(c) The construction of cumulative frequency table is useful in determining the Median.

(d)

Time (in sec)	No. of students(f)	Cf
0 - 20	8	8
20 - 40	10	18
40 - 60	13	31
60 - 80	6	37
80 - 100	3	40
	$N = \Sigma f = 40$	



Here  $N/2 = 40/2 = 20$ , Median Class = 40 – 60, Modal Class = 40 – 60  
 Sum of upper limits of median class and modal class = 60 + 60 = 120  
 (e) Number of students who finished the race within 80 seconds  
 = 8 + 10 + 13 + 6 = 37

## Part B

### Section III

21. Let AB be the diameter of the given circle, and let PQ and RS be the tangent lines drawn to the circle at points A and B respectively.

Since tangent at a point to a circle is perpendicular to the radius through the point of contact.

Therefore, AB is perpendicular to both PQ and RS.

$\Rightarrow \angle PAB = 90^\circ$  and  $\angle ABS = 90^\circ$

$\Rightarrow \angle PAB = \angle ABS$

But, these are a pair of alternate interior angles.

Therefore, PQ is parallel to RS.

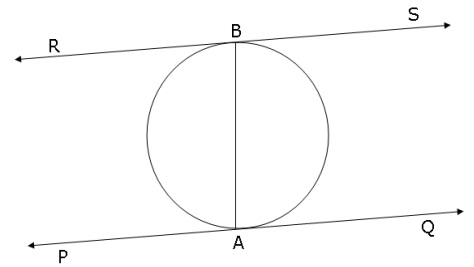

22. Circumference of first circle =  $C_1 = 2\pi \times 19 = 38\pi$   
 Circumference of second circle =  $C_2 = 2\pi \times 9 = 18\pi$   
 $C_1 + C_2 = 56\pi$   
 Let R be the radius of the new circle.  
 $\therefore 2\pi R = 56\pi$   
 $\therefore 2R = 56$   
 $\therefore R = 28$  cm

OR

Dimension of the rectangular cardboard = 14 cm  $\times$  7 cm

Since, two circular pieces of equal radii and maximum area touching each other are cut from the rectangular card board, therefore, the diameter of each circular piece is  $14/2 = 7$  cm.

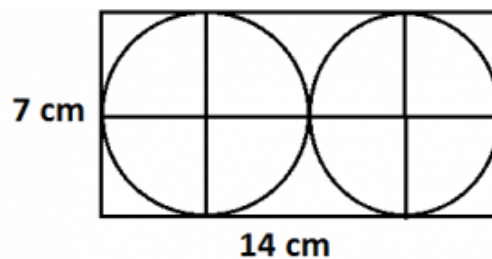

$$\therefore \text{Area of each circle} = \frac{22}{7} \times \frac{7}{2} \times \frac{7}{2} = \frac{77}{2} \text{ cm}^2$$

$$\Rightarrow \text{Area of two circles} = 2 \times \frac{77}{2} = 77 \text{ cm}^2$$

$$\text{Area of rectangular cardboard} = 14 \times 7 = 98 \text{ cm}^2$$

Thus, area of remaining cardboard

$$= \text{Area of rectangular cardboard} - \text{Area of two circles}$$

$$= (98 - 77) \text{ cm}^2$$

$$= 21 \text{ cm}^2$$

**23.** Given: Height of the cylindrical part ( $h$ ) = 10cm

Radius ( $r$ ) of cylindrical part = radius ( $r$ ) of hemispherical part = 3.5cm

Surface area of article = CSA of cylindrical part +  $2 \times$ CSA of hemispherical part

$$= 2\pi rh + 2 \times 2\pi r^2$$

$$= 2\pi \times 3.5 \times 10 + 2 \times 2\pi \times 3.5 \times 3.5$$

$$= 70\pi + 49\pi$$

$$= 119\pi$$

$$= 17 \times 22 = 374 \text{ cm}^2$$

Hence, the surface area of the article is 374 cm<sup>2</sup>.

**24.** Let AC be the electric pole of height 4 m. Let B be a point 1.3 m below the top A of the pole AC.

Then, BC = AC - AB = 4 - 1.3 = 2.7 m

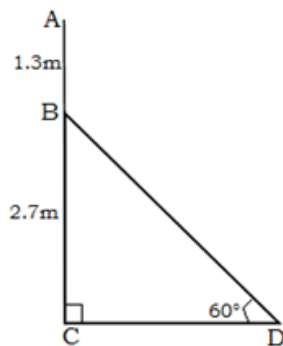

Let BD be the length of ladder inclined at an angle of 60°.

$$\sin 60^\circ = \frac{BC}{BD}$$

$$\Rightarrow \frac{\sqrt{3}}{2} = \frac{2.7}{BD}$$

$$\Rightarrow BD = \frac{5.4}{\sqrt{3}} = 1.8\sqrt{3} \text{ or } \frac{9\sqrt{3}}{5}$$

Thus, the length of the ladder is  $\frac{9\sqrt{3}}{5}$  m.



OR

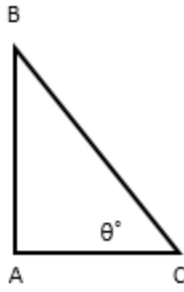

Let AB be the pole and let AC be its shadow.

Let the angle of elevation of the sun be  $\theta^\circ$ .

$\angle ACB = \theta$ ,  $\angle CAB = 90^\circ$

AB = 10 m and AC =  $10\sqrt{3}$  m

In  $\Delta CAB$ ,

$$\tan \theta = \frac{AB}{AC} = \frac{10}{10\sqrt{3}} = \frac{1}{\sqrt{3}}$$

$$\Rightarrow \theta = 30$$

Hence, the angular elevation of the sun is  $30^\circ$ .

25. The given AP is  $\sqrt{2}, \sqrt{8}, \sqrt{18}, \dots$  or  $\sqrt{2}, 2\sqrt{2}, 3\sqrt{2}, \dots$

Common difference  $d = 2\sqrt{2} - \sqrt{2} = \sqrt{2}$

Term next to  $3\sqrt{2} = 3\sqrt{2} + d = 3\sqrt{2} + \sqrt{2} = 4\sqrt{2} = \sqrt{16 \times 2} = \sqrt{32}$

26. A die is thrown at once then  $S = \{1, 2, 3, 4, 5, 6\}$

$$\therefore n(S) = 6$$

Let E be the event of getting a prime number.

$$\therefore E = \{2, 3, 5\}$$

$$\therefore n(E) = 3$$

$$\therefore P(E) = \frac{n(E)}{n(S)} = \frac{3}{6} = \frac{1}{2}$$

### Section IV

27. Suppose the line  $3x + y - 9 = 0$  divides the line segment joining the points A(1, 3) and B(2, 7) in the ratio  $k : 1$  at point C.

Then, the co-ordinates of C are  $\left( \frac{2k + 1}{k + 1}, \frac{7k + 3}{k + 1} \right)$

But, C lies on  $3x + y - 9 = 0$ .

Therefore,

$$\left[ 3 \left( \frac{2k + 1}{k + 1} \right) \right] + \left[ \frac{7k + 3}{k + 1} \right] - 9 = 0$$

$$\Rightarrow 6k + 3 + 7k + 3 - 9k - 9 = 0$$

$$\Rightarrow 4k - 3 = 0$$

$$\Rightarrow k = \frac{3}{4}$$

So, the required ratio is 3: 4.

**OR**

Given, the point P divides the join of (2, 1) and (-3, 6) in the ratio 2: 3.

$$\text{Co-ordinates of the point P} = \left( \frac{2 \times (-3) + 3 \times 2}{2 + 3}, \frac{2 \times 6 + 3 \times 1}{2 + 3} \right) = \left( \frac{-6 + 6}{5}, \frac{12 + 3}{5} \right) = (0, 3)$$

Now, the given equation is  $x - 5y + 15 = 0$ .

Substituting  $x = 0$  and  $y = 3$  in this equation, we have

$$\text{L.H.S.} = 0 - 5(3) + 15 = -15 + 15 = 0 = \text{R.H.S.}$$

Hence, the point P lies on the line  $x - 5y + 15 = 0$ .

**28.**

1. Draw a line segment of AB length 7.6 cm.
2. Draw a ray AX making acute angle with AB and take 13 points  $A_1, A_2, \dots, A_{13}$  on it at equal distances
3. Join  $A_{13}$  and B. Draw line parallel to  $A_{13}B$  from  $A_5$  meeting AB at C.
4.  $AC: CB = 5:8$ . Measuring the lengths, we get  $AC = 2.9$  cm and  $CB = 4.7$  cm.

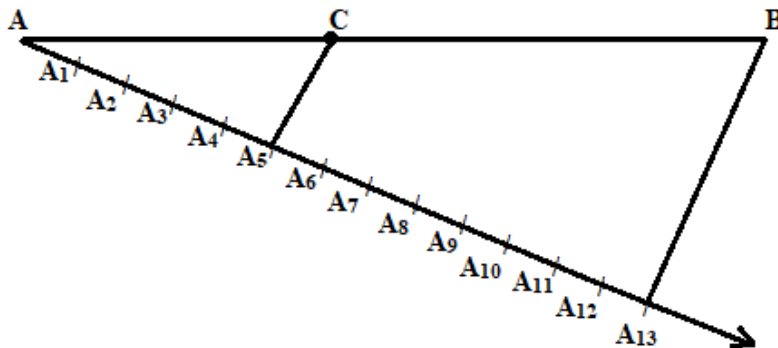

- 29.** Since, the highest frequency is between 35 – 45 we have  $l = 35$ ,  $h = 10$ ,  $f_0 = 21$ ,  $f_1 = 23$ ,  $f_2 = 14$

$$\text{Mode} = l + \frac{(f_1 - f_0)}{(2f_1 - f_0 - f_2)} \times h = 35 + \frac{(23 - 21)}{(2 \times 23 - 21 - 14)} \times 10 = 36.8$$

$$\text{Mean } \bar{x} = \frac{\sum f_i x_i}{\sum f_i} = \frac{2830}{80} = 35.375$$

**OR**

From the data given as above we may observe that maximum class frequency is 12 belonging to class interval 65 – 75.

So, modal class = 65 – 75

Lower class limit ( $l$ ) of modal class = 65

Frequency ( $f_1$ ) of modal class = 12

Frequency ( $f_0$ ) of class preceding the modal class = 11

Frequency ( $f_2$ ) of class succeeding the modal class = 9

Class size (h) = 10

$$\begin{aligned}\text{Mode} &= l + \left( \frac{f_1 - f_0}{2f_1 - f_0 - f_2} \right) \times h = 65 + \left( \frac{12 - 11}{2(12) - 11 - 9} \right) \times 10 \\ &= 65 + \frac{1}{4} \times 10 = 65 + 2.5 = 67.5\end{aligned}$$

**30.**

The numbers of the form  $\frac{p}{q}$ , where p and q are integers

and  $q \neq 0$  are called rational numbers.

Let  $x = \overline{3.1416}$

$$\Rightarrow x = 3.141614161416\dots \dots \dots \text{... (i)}$$

Since there are four repeating digits,  
we multiply by 1000.

$$\Rightarrow 10000x = 31416.14161416\dots \dots \dots \text{... (ii)}$$

Subtracting (i) from (ii), we get

$$9999x = 31413$$

$$\Rightarrow x = \frac{31413}{9999} \text{ which is of the form } \frac{p}{q}.$$

So,  $\overline{3.1416}$  is a rational number.

**31.** Dividend,  $p(x) = x^3 - 3x^2 + x + 2$

Quotient =  $(x - 2)$

Remainder =  $(-2x + 4)$

Let  $g(x)$  be the divisor.

According to the division algorithm,

Dividend = Divisor  $\times$  Quotient + Remainder

$$x^3 - 3x^2 + x + 2 = g(x) \times (x - 2) + (-2x + 4)$$

$$\Rightarrow x^3 - 3x^2 + x + 2 + 2x - 4 = g(x)(x - 2)$$

$$\Rightarrow x^3 - 3x^2 + 3x - 2 = g(x)(x - 2)$$

Now,  $g(x)$  is the quotient when  $x^3 - 3x^2 + 3x - 2$  is divided by  $x - 2$



$$\begin{array}{r}
 x-2 \overline{) \begin{array}{l} x^2 - x + 1 \\ x^3 - 3x^2 + 3x - 2 \\ \hline x^3 - 2x^2 \\ \hline -x^2 + 3x - 2 \\ \hline -x^2 + 2x \\ \hline + \quad - \\ \hline x - 2 \\ \hline x - 2 \\ \hline - \quad + \\ \hline 0 \end{array} } \\
 \end{array}$$

$$\therefore g(x) = x^2 - x + 1$$

32. Let the fraction be  $\frac{x}{y}$ .

According to the question,

$$x + y = 8 \quad \dots(1)$$

$$\frac{x+3}{y+3} = \frac{3}{4}$$

$$\Rightarrow 4x + 12 = 3y + 9$$

$$\Rightarrow 4x - 3y = -3 \quad \dots(2)$$

Multiplying (1) by 3, we get

$$3x + 3y = 24 \quad \dots(3)$$

Adding (2) and (3), we get

$$7x = 21$$

$$\Rightarrow x = 3$$

$$\Rightarrow y = 8 - x = 8 - 3 = 5$$

Thus, the fraction is  $\frac{3}{5}$ .

33. Radius ( $r$ ) of circle = 21 cm

Angle subtended by given arc =  $60^\circ$

Length of an arc of a sector of angle  $\theta = \frac{\theta}{360^\circ} \times 2\pi r$

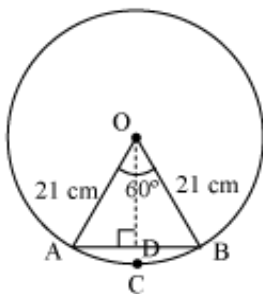

$$\begin{aligned} \text{a. Length of arc ACB} &= \frac{60^\circ}{360^\circ} \times 2 \times \frac{22}{7} \times 21 \\ &= \frac{1}{6} \times 2 \times 22 \times 3 = 22 \text{ cm} \end{aligned}$$

$$\begin{aligned} \text{b. Area of sector OACB} &= \frac{60^\circ}{360^\circ} \times \pi r^2 \\ &= \frac{1}{6} \times \frac{22}{7} \times 21 \times 21 \\ &= 231 \text{ cm}^2 \end{aligned}$$

c. Now in  $\Delta OAB$   
 $\angle OAB = \angle OBA$  (as  $OA = OB$ )...(i)  
 $\angle OAB + \angle AOB + \angle OBA = 180^\circ$   
 $\Rightarrow 2\angle OAB + 60^\circ = 180^\circ$  ....from(i)  
 $\Rightarrow \angle OAB = 60^\circ$

So,  $\Delta OAB$  is an equilateral triangle.

$$\begin{aligned} \text{Area of } \Delta OAB &= \frac{\sqrt{3}}{4} \times (\text{side})^2 \\ &= \frac{\sqrt{3}}{4} \times (21)^2 = \frac{441\sqrt{3}}{4} \text{ cm}^2 \end{aligned}$$

Area of segment ACB = Area of sector OACB – Area of  $\Delta OAB$

$$= \left( 231 - \frac{441\sqrt{3}}{4} \right) \text{ cm}^2$$

**OR**

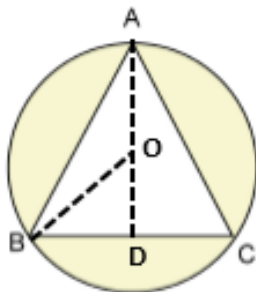

Let  $O$  be the centre of the circumcircle.

Join  $OB$  and draw  $AD \perp BC$ .

Then,  $OB = 42 \text{ cm}$  and  $\angle OBD = 30^\circ$

In  $\Delta OBD$ ,

$$\sin 30^\circ = \frac{OD}{OB}$$

$$\Rightarrow \frac{1}{2} = \frac{OD}{42}$$

$$\Rightarrow OD = 21 \text{ cm}$$

$$\text{Now, } BD^2 = OB^2 - OD^2 = 42^2 - 21^2 = (42 + 21)(42 - 21) = 63 \times 21$$

$$\Rightarrow BD = \sqrt{63 \times 21} = \sqrt{3 \times 21 \times 21} = 21\sqrt{3} \text{ cm}$$

$$\Rightarrow BC = 2 \times 21\sqrt{3} = 42\sqrt{3} \text{ cm}$$

Now, area of the shaded region

= Area of the circle - Area of an equilateral  $\triangle ABC$

$$= \frac{22}{7} \times 42 \times 42 - \frac{\sqrt{3}}{4} \times 42\sqrt{3} \times 42\sqrt{3}$$

$$= (5544 - 2291.5) \text{ cm}^2$$

$$= 3252.5 \text{ cm}^2$$

## Section V

34. Let B be the window of a house AB and let CD be the other house.

Then,  $AB = EC = h$  metres.

Let  $CD = H$  metres.

Then,  $ED = (H - h)$  m

In  $\triangle BED$ ,

$$\cot \alpha = \frac{BE}{ED}$$

$$BE = (H - h) \cot \alpha \quad \dots (a)$$

In  $\triangle ACB$ ,

$$\frac{AC}{AB} = \cot \beta$$

$$AC = h \cdot \cot \beta \quad \dots (b)$$

But  $BE = AC$

$$\therefore (H - h) \cot \alpha = h \cot \beta \quad \dots [\text{From (a) and (b)}]$$

$$H = h \frac{(\cot \alpha + \cot \beta)}{\cot \alpha}$$

$$H = h(1 + \tan \alpha \cot \beta)$$

Thus, the height of the opposite house is  $h(1 + \tan \alpha \cot \beta)$  metres

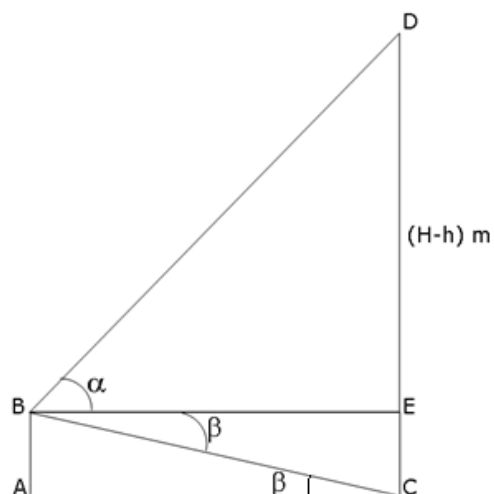

OR

Let AD represent the light house.

Let the points B and C denote the ships based on the opposite sides of the light house.

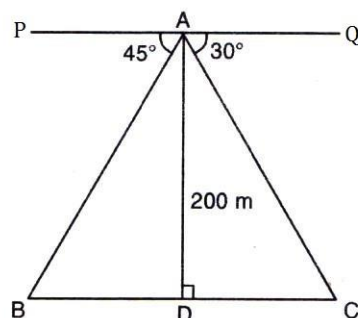

$\angle ABD = \angle PAB = 45^\circ$  (interior alternate angle)

$\angle ACD = \angle QAC = 30^\circ$  (interior alternate angle)

$$\therefore \tan 45^\circ = \frac{AD}{BD} \Rightarrow 1 = \frac{200}{BD} \Rightarrow BD = 200 \text{ m}$$

$$\text{Also, } \tan 30^\circ = \frac{AD}{DC}$$

$$\Rightarrow \frac{1}{\sqrt{3}} = \frac{200}{DC} \Rightarrow DC = 200\sqrt{3} \text{ m}$$

$$\Rightarrow DC = 200 \times 1.732 = 346.4 \text{ m}$$

$$\therefore BC = BD + DC = (200 + 346.4) \Rightarrow BC = 546.4 \text{ m}$$

Distance between two ships = 546.4 m

**35. Statement :** Ratio of the areas of two similar triangles is equal to the ratio of the squares of their corresponding sides.

**Given :** Two triangles ABC and PQR such that  $\triangle ABC \sim \triangle PQR$

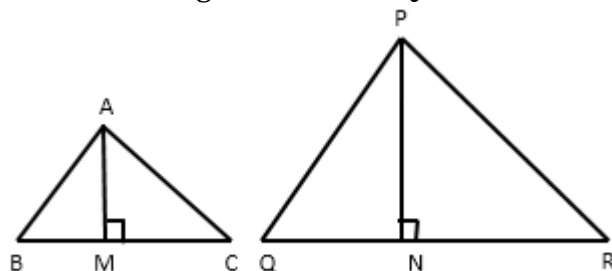

$$\text{To prove : } \frac{\text{ar}(\triangle ABC)}{\text{ar}(\triangle PQR)} = \frac{AB^2}{PQ^2} = \frac{BC^2}{QR^2} = \frac{CA^2}{RP^2}$$

**Proof :**

For finding the areas of the two triangles, we draw altitudes AM and PN of the triangles.

$$\text{Now, } \text{ar}(\triangle ABC) = \frac{1}{2} BC \times AM$$

$$\text{And } \text{ar}(\triangle PQR) = \frac{1}{2} QR \times PN$$

$$\text{So, } \frac{\text{ar}(\triangle ABC)}{\text{ar}(\triangle PQR)} = \frac{\frac{1}{2} \times BC \times AM}{\frac{1}{2} \times QR \times PN} = \frac{BC \times AM}{QR \times PN} \dots(1)$$

Now, in  $\triangle ABM$  and  $\triangle PQN$ .

$$\angle B = \angle Q \quad (\text{As } \triangle ABC \sim \triangle PQR)$$

$$\angle M = \angle N \quad (\text{Each} = 90^\circ)$$

So,  $\triangle ABM \sim \triangle PQN$  (AA similarity criterion)

$$\text{Therefore, } \frac{AM}{PN} = \frac{AB}{PQ} \dots(2)$$

Also,  $\triangle ABC \sim \triangle PQR$

$$\text{So, } \frac{AB}{PQ} = \frac{BC}{QR} = \frac{CA}{RP} \dots(3)$$

$$\frac{\text{ar}(ABC)}{\text{ar}(PQR)} = \frac{AB}{PQ} \times \frac{AM}{PN} \quad [\text{from (1) and (3)}]$$

$$= \frac{AB}{PQ} \times \frac{AB}{PQ} \quad [\text{from (2)}]$$

$$= \left( \frac{AB}{PQ} \right)^2$$

Now using (3), we get

$$\frac{\text{ar}(ABC)}{\text{ar}(PQR)} = \frac{AB^2}{PQ^2}$$

Similarly

$$\frac{\text{ar}(ABC)}{\text{ar}(PQR)} = \frac{BC^2}{QR^2} = \frac{CA^2}{RP^2}$$

**36.** Length of the cylinder = 24 cm

Diameter of copper wire = 4 mm = 0.4 cm

Therefore, the number of rounds required for a wire to cover the length of cylinder

$$= \frac{\text{Length of cylinder}}{\text{Thickness of wire}}$$

$$= \frac{24 \text{ cm}}{0.4 \text{ cm}}$$

$$= 60$$

Now, diameter of cylinder = 20 cm

Therefore, length of the wire required to complete one round = circumference of

$$\text{base of the cylinder} = \pi d = \frac{22}{7} \times 20 = \frac{440}{7} \text{ cm}$$

Length of wire for covering the whole surface of cylinder

= length of wire in completing 60 rounds

$$= 60 \times \frac{440}{7} = 3771.428 \text{ cm}$$

$$\text{Radius of copper wire} = \frac{0.4}{2} \text{ cm} = 0.2 \text{ cm}$$

$$\text{Therefore, volume of wire} = \pi r^2 h = \frac{22}{7} \times (0.2)^2 \times 3771.428 = 474.122 \text{ cm}^3$$

Weight of wire = volume  $\times$  density

$$= 474.122 \times 8.68 = 4115.38 \text{ g} = 4.11538 \text{ kg} \approx 4.12 \text{ kg}$$

